

7/16-3200B-L600

7/16 Plug Clamp For JBY600, LMR600
6GHz VSWR1.2

50Ω

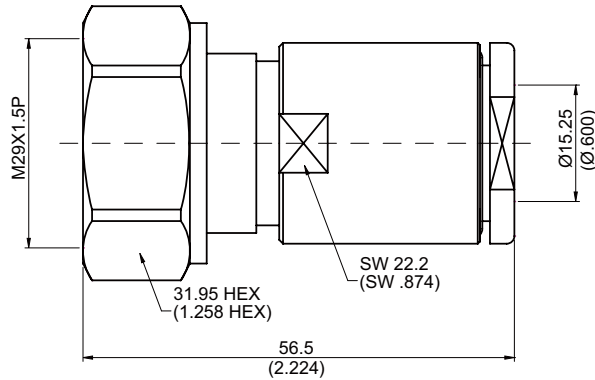

Note : Spring finger design ensures easy assembly

Parts	Material	Plating(Micro-inch)
Retainer Ring	Brass	Tin-Zinc-Copper-Alloy 100 Over Copper 50
Gasket	Silicon	
Nut	Brass	Tin-Zinc-Copper-Alloy 100 Over Copper 50
Washer	Brass	Tin-Zinc-Copper-Alloy 100 Over Copper 50
Braid Clamp	Brass	Tin-Zinc-Copper-Alloy 100 Over Copper 50
Barrel	Brass	Tin-Zinc-Copper-Alloy 100 Over Copper 50
Contact Pin	Brass	Gold 4 Over Nickel-Phosphorus Alloy 80 Over Copper 20
Insulator	Teflon	
Body	Brass	Tin-Zinc-Copper-Alloy 100 Over Copper 50
Coupling Nut	Brass	Tin-Zinc-Copper-Alloy 100 Over Copper 50

Weight: 177.88

Suitable Cables: JBY600

This part number complies with RoHS.

Notice: JYEBAO reserves the right to make modifications deemed appropriate.

7/16	7/16-3200B-L600																				
<div style="border: 1px solid black; padding: 2px; margin-bottom: 5px;">Interface</div> <p>IEC 60169-4</p>																					
<div style="border: 1px solid black; padding: 2px; margin-bottom: 5px;">Electrical Data</div> <table style="width: 100%; border-collapse: collapse;"> <tr> <td style="width: 60%;">Impedance</td> <td style="text-align: right;">50Ω</td> </tr> <tr> <td>Frequency range</td> <td style="text-align: right;">DC to 6GHz</td> </tr> <tr> <td>VSWR</td> <td style="text-align: right;">≦ 1.2 (DC to 6GHz)</td> </tr> <tr> <td>Insertion loss</td> <td style="text-align: right;">≦ 0.05dB</td> </tr> <tr> <td>Insulation resistance</td> <td style="text-align: right;">≧ 10000MΩ</td> </tr> <tr> <td>Contact resistance inner conductor</td> <td style="text-align: right;">≦ 0.4mΩ</td> </tr> <tr> <td>Contact resistance outer conductor</td> <td style="text-align: right;">≦ 1.5mΩ</td> </tr> <tr> <td>Dielectric withstanding voltage (at sea level)</td> <td style="text-align: right;">4000 V rms</td> </tr> <tr> <td>Working Voltage (at sea level)</td> <td style="text-align: right;">2700 V rms</td> </tr> <tr> <td>Rf leakage</td> <td style="text-align: right;">≧ 128dB to 1GHz</td> </tr> </table>		Impedance	50Ω	Frequency range	DC to 6GHz	VSWR	≦ 1.2 (DC to 6GHz)	Insertion loss	≦ 0.05dB	Insulation resistance	≧ 10000MΩ	Contact resistance inner conductor	≦ 0.4mΩ	Contact resistance outer conductor	≦ 1.5mΩ	Dielectric withstanding voltage (at sea level)	4000 V rms	Working Voltage (at sea level)	2700 V rms	Rf leakage	≧ 128dB to 1GHz
Impedance	50Ω																				
Frequency range	DC to 6GHz																				
VSWR	≦ 1.2 (DC to 6GHz)																				
Insertion loss	≦ 0.05dB																				
Insulation resistance	≧ 10000MΩ																				
Contact resistance inner conductor	≦ 0.4mΩ																				
Contact resistance outer conductor	≦ 1.5mΩ																				
Dielectric withstanding voltage (at sea level)	4000 V rms																				
Working Voltage (at sea level)	2700 V rms																				
Rf leakage	≧ 128dB to 1GHz																				
<div style="border: 1px solid black; padding: 2px; margin-bottom: 5px;">Mechanical Data</div> <table style="width: 100%; border-collapse: collapse;"> <tr> <td style="width: 60%;">Recommended coupling nut torque</td> <td style="text-align: right;">260 inch lbs</td> </tr> <tr> <td>Coupling proof torque</td> <td style="text-align: right;">310 inch lbs</td> </tr> <tr> <td>Coupling nut retention force</td> <td style="text-align: right;">≧ 221 lbs</td> </tr> <tr> <td>Contact captivation-axial</td> <td style="text-align: right;">≧ 45 lbs</td> </tr> <tr> <td>Durability (mating)</td> <td style="text-align: right;">≧ 500</td> </tr> </table>		Recommended coupling nut torque	260 inch lbs	Coupling proof torque	310 inch lbs	Coupling nut retention force	≧ 221 lbs	Contact captivation-axial	≧ 45 lbs	Durability (mating)	≧ 500										
Recommended coupling nut torque	260 inch lbs																				
Coupling proof torque	310 inch lbs																				
Coupling nut retention force	≧ 221 lbs																				
Contact captivation-axial	≧ 45 lbs																				
Durability (mating)	≧ 500																				
<div style="border: 1px solid black; padding: 2px; margin-bottom: 5px;">Environmental Data</div> <table style="width: 100%; border-collapse: collapse;"> <tr> <td style="width: 60%;">Temperature range</td> <td style="text-align: right;">-65°C to +165°C</td> </tr> <tr> <td>Thermal shock</td> <td style="text-align: right;">MIL-STD-202, Method107, Condition B</td> </tr> <tr> <td>Moisture resistance</td> <td style="text-align: right;">MIL-STD-202, Method106</td> </tr> <tr> <td>Corrosion</td> <td style="text-align: right;">MIL-STD-202, Method101, Condition B</td> </tr> <tr> <td>RoHS</td> <td style="text-align: right;">Compliant</td> </tr> </table>		Temperature range	-65°C to +165°C	Thermal shock	MIL-STD-202, Method107, Condition B	Moisture resistance	MIL-STD-202, Method106	Corrosion	MIL-STD-202, Method101, Condition B	RoHS	Compliant										
Temperature range	-65°C to +165°C																				
Thermal shock	MIL-STD-202, Method107, Condition B																				
Moisture resistance	MIL-STD-202, Method106																				
Corrosion	MIL-STD-202, Method101, Condition B																				
RoHS	Compliant																				
<div style="border: 1px solid black; padding: 2px; margin-bottom: 5px;">Tooling</div>																					

Notice: JYEBAO reserves the right to make modifications deemed appropriate.

JYE BAO CO., LTD.

CABLE ASSEMBLY INSTRUCTION

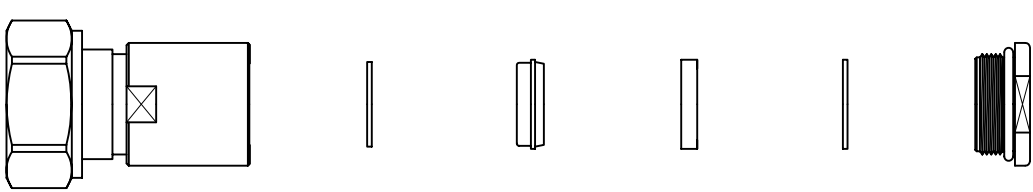
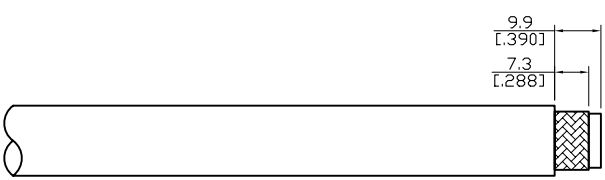
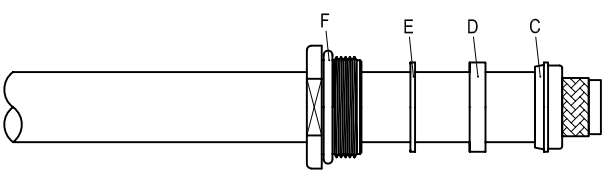
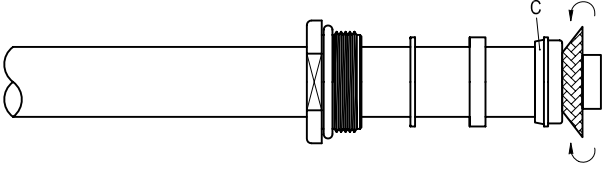
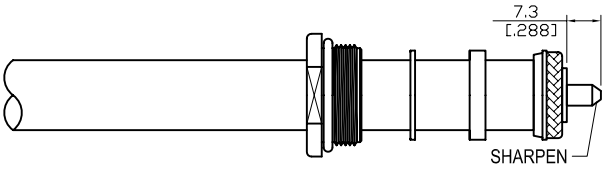
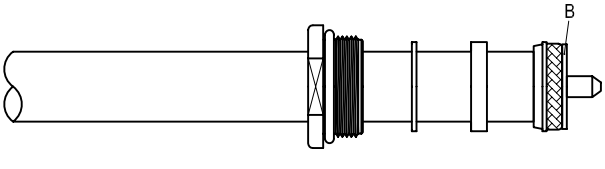
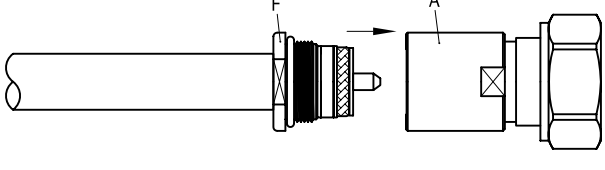
7/16-3200B-L600	DATE	2017/03/27	REV	—
<div style="display: flex; justify-content: space-around; margin-bottom: 10px;"> A B C D E F </div>  <div style="display: flex; justify-content: space-around; margin-top: 10px;"> BODY WASHER BRAID CLAMP GASKET WASHER NUT + GASKET </div>				
DIAGRAM	ASSEMBLY INSTRUCTION			
	Step 1: STRIP AS SHOWN.			
	Step 2: SLIDE NUT " F " 、 WASHER " E " 、 GASKET " D " AND BRAID CLAMP " C " OVER CABLE.			
	Step 3: WRAP THE BRAIDING OVER " C " .			
	Step 4: STRIP AS SHOWN. Step 5: SHARPEN CENTER CONDUCTOR TIP.			
	Step 6: SLIDE PREPARED CABLE INTO WASHER " B " .			
	Step 7: FINALLY SCREW " F " ON THE CONNECTOR BODY " A " .			
<p>This part number complies with RoHS.</p> <p>Notice: JYEBAO reserves the right to make modifications deemed appropriate.</p>				
APPROVED	CHECKED	DRAWING		<i>Albert</i>

7/16-3200B-L600

S11

