

7/16-3100-L400      7/16 Plug Crimp For JBY400,LMR400; 50Ω  
3.6GHz VSWR 1.2

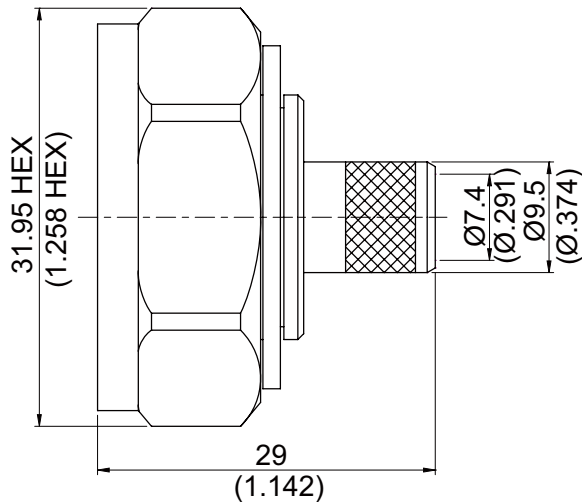

NOTE: Comes with protective dust cap.

Parts	Material	Plating(Micro-inch)
Ferrule	Brass	Tin-Zinc-Copper-Alloy 100 Over Copper 50
E-ring	Stainless Steel	Passivated
Gasket	Silicone	
Small Pin	Brass	Gold 4 Over Nickel-Phosphorus Alloy 80 Over Copper 20
Contact Pin	Phosphor Bronze	Gold 4 Over Nickel-Phosphorus Alloy 80 Over Copper 20
Insulator	Teflon	
Body	Brass	Tin-Zinc-Copper-Alloy 100 Over Copper 50
Dust Cap	PVC	
Coupling Nut	Brass	Tin-Zinc-Copper-Alloy 100 Over Copper 50

Suitable Cables: JBY400, LMR400

This part number complies with RoHS.





Notice: JYEBAO reserves the right to make modifications deemed appropriate.

7/16	7/16-3100-L400																				
<div style="border: 1px solid black; padding: 2px; display: inline-block;">Interface</div> IEC 60169-4																					
<div style="border: 1px solid black; padding: 2px; display: inline-block;">Electrical Data</div> <table style="width: 100%; border-collapse: collapse;"> <tr> <td style="width: 60%;">Impedance</td> <td style="text-align: right;">50Ω</td> </tr> <tr> <td>Frequency range</td> <td style="text-align: right;">DC to 3.6GHz</td> </tr> <tr> <td>VSWR</td> <td style="text-align: right;">≦ 1.2 (DC to 3.6GHz)</td> </tr> <tr> <td>Insertion loss</td> <td style="text-align: right;">≦ 0.05dB</td> </tr> <tr> <td>Insulation resistance</td> <td style="text-align: right;">≧ 10000MΩ</td> </tr> <tr> <td>Contact resistance inner conductor</td> <td style="text-align: right;">≦ 0.4mΩ</td> </tr> <tr> <td>Contact resistance outer conductor</td> <td style="text-align: right;">≦ 1.5mΩ</td> </tr> <tr> <td>Dielectric withstanding voltage (at sea level)</td> <td style="text-align: right;">4000 V rms</td> </tr> <tr> <td>Working Voltage (at sea level)</td> <td style="text-align: right;">2700 V rms</td> </tr> <tr> <td>Rf leakage</td> <td style="text-align: right;">≧ 1 28dB to 1GHz</td> </tr> </table>		Impedance	50Ω	Frequency range	DC to 3.6GHz	VSWR	≦ 1.2 (DC to 3.6GHz)	Insertion loss	≦ 0.05dB	Insulation resistance	≧ 10000MΩ	Contact resistance inner conductor	≦ 0.4mΩ	Contact resistance outer conductor	≦ 1.5mΩ	Dielectric withstanding voltage (at sea level)	4000 V rms	Working Voltage (at sea level)	2700 V rms	Rf leakage	≧ 1 28dB to 1GHz
Impedance	50Ω																				
Frequency range	DC to 3.6GHz																				
VSWR	≦ 1.2 (DC to 3.6GHz)																				
Insertion loss	≦ 0.05dB																				
Insulation resistance	≧ 10000MΩ																				
Contact resistance inner conductor	≦ 0.4mΩ																				
Contact resistance outer conductor	≦ 1.5mΩ																				
Dielectric withstanding voltage (at sea level)	4000 V rms																				
Working Voltage (at sea level)	2700 V rms																				
Rf leakage	≧ 1 28dB to 1GHz																				
<div style="border: 1px solid black; padding: 2px; display: inline-block;">Mechanical Data</div> <table style="width: 100%; border-collapse: collapse;"> <tr> <td style="width: 60%;">Recommended coupling nut torque</td> <td style="text-align: right;">260 inch lbs</td> </tr> <tr> <td>Coupling proof torque</td> <td style="text-align: right;">310 inch lbs</td> </tr> <tr> <td>Coupling nut retention force</td> <td style="text-align: right;">≧ 221 lbs</td> </tr> <tr> <td>Contact captivation-axial</td> <td style="text-align: right;">≧ 45 lbs</td> </tr> <tr> <td>Durability (mating)</td> <td style="text-align: right;">≧ 500</td> </tr> </table>		Recommended coupling nut torque	260 inch lbs	Coupling proof torque	310 inch lbs	Coupling nut retention force	≧ 221 lbs	Contact captivation-axial	≧ 45 lbs	Durability (mating)	≧ 500										
Recommended coupling nut torque	260 inch lbs																				
Coupling proof torque	310 inch lbs																				
Coupling nut retention force	≧ 221 lbs																				
Contact captivation-axial	≧ 45 lbs																				
Durability (mating)	≧ 500																				
<div style="border: 1px solid black; padding: 2px; display: inline-block;">Environmental Data</div> <table style="width: 100%; border-collapse: collapse;"> <tr> <td style="width: 60%;">Temperature range</td> <td style="text-align: right;">-65°C to +165°C</td> </tr> <tr> <td>Thermal shock</td> <td style="text-align: right;">MIL-STD-202, Method107, Condition B</td> </tr> <tr> <td>Moisture resistance</td> <td style="text-align: right;">MIL-STD-202, Method106</td> </tr> <tr> <td>Corrosion</td> <td style="text-align: right;">MIL-STD-202, Method101, Condition B</td> </tr> <tr> <td>RoHS</td> <td style="text-align: right;">Compliant</td> </tr> </table>		Temperature range	-65°C to +165°C	Thermal shock	MIL-STD-202, Method107, Condition B	Moisture resistance	MIL-STD-202, Method106	Corrosion	MIL-STD-202, Method101, Condition B	RoHS	Compliant										
Temperature range	-65°C to +165°C																				
Thermal shock	MIL-STD-202, Method107, Condition B																				
Moisture resistance	MIL-STD-202, Method106																				
Corrosion	MIL-STD-202, Method101, Condition B																				
RoHS	Compliant																				
<div style="border: 1px solid black; padding: 2px; display: inline-block;">Tooling</div> <table style="width: 100%; border-collapse: collapse;"> <tr> <td style="width: 60%;">Crimping tool</td> <td style="text-align: right;">CRT-1 or CRT-2</td> </tr> <tr> <td>Crimp insert</td> <td style="text-align: right;">INSERT-C</td> </tr> </table>		Crimping tool	CRT-1 or CRT-2	Crimp insert	INSERT-C																
Crimping tool	CRT-1 or CRT-2																				
Crimp insert	INSERT-C																				

Notice: JYEBAO reserves the right to make modifications deemed appropriate.

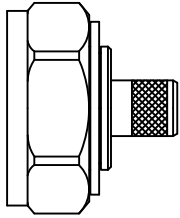
# JYE BAO CO., LTD.

## CABLE ASSEMBLY INSTRUCTION

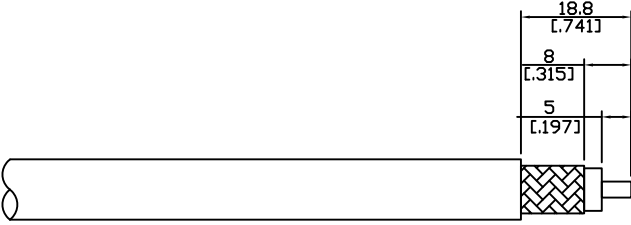
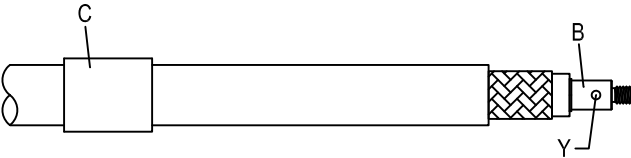
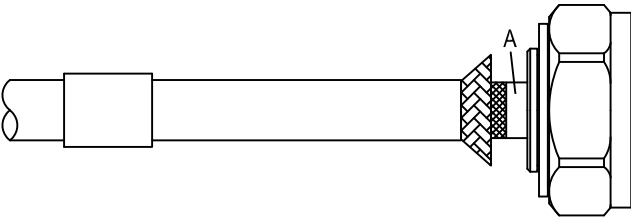
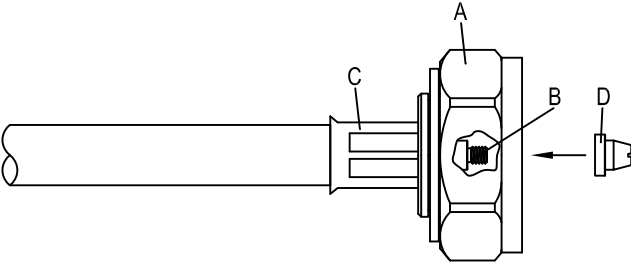
7/16-3100-L400	DATE	2018/06/01	REV	—
<p style="text-align: center;">A</p>  <p style="text-align: center;">BODY</p>	<p style="text-align: center;">B</p>  <p style="text-align: center;">CONTACT PIN</p>	<p style="text-align: center;">C</p>  <p style="text-align: center;">FERRULE</p>	<p style="text-align: center;">D</p>  <p style="text-align: center;">CONTACT PIN</p>	
<p style="text-align: center;">DIAGRAM</p>	<p style="text-align: center;">ASSEMBLY INSTRUCTION</p>			
	<p>Step 1: STRIP AS SHOWN.</p>			
	<p>Step 2: SLIDE FERRULE " C " OVER CABLE. Step 3: PUT PIN " B " ON CENTER CONDUCTOR AND SOLDER IN " Y ".</p>			
	<p>Step 4: LOOSEN BRAIDING AND SLIDE CONNECTOR " A " IN PLACE.</p>			
	<p>Step 5: SCREW CONTACT PIN " D " ON CONTACT PIN " B ". Step 6: SLIDE FERRULE " C " TOWARDS THE CONNECTOR " A " AND CRIMP. (USE 10.7mm/0.421inch HEX SECTION OF INSERT-C)</p>			
<p>This part number complies with RoHS. Notice: JYEBAO reserves the right to make modifications deemed appropriate.</p>				
APPROVED	CHECKED	DRAWING		<i>Albert</i>

# 7/16-3100-L400

S11

