

7/16-3100-0142

7/16 plug crimp for RG142, RG400;
0.7GHz VSWR 1.2

50Ω

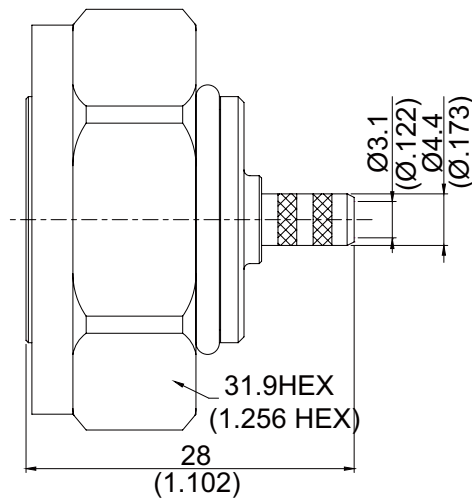

Parts	Material	Plating(Micro-inch)
Ferrule	Brass	Tin-Zinc-Copper-Alloy 100 Over Copper 50
Gasket	Silicon	
Contact Pin	Brass	Gold 4 Over Nickel-Phosphorus Alloy 80 Over Copper 20
Insulator	Teflon	
Body	Brass	Tin-Zinc-Copper-Alloy 100 Over Copper 50
Coupling Nut	Brass	Tin-Zinc-Copper-Alloy 100 Over Copper 50

Suitable Cables: RG55, RG142, RG400

This part number complies with RoHS.





Notice: JYEBAO reserves the right to make modifications deemed appropriate.

7/16	7/16-3100-0142																				
<div style="border: 1px solid black; padding: 2px; margin-bottom: 5px;">Interface</div> <p>IEC 60169-4</p>																					
<div style="border: 1px solid black; padding: 2px; margin-bottom: 5px;">Electrical Data</div> <table style="width: 100%; border-collapse: collapse;"> <tr> <td style="width: 60%;">Impedance</td> <td style="text-align: right;">50Ω</td> </tr> <tr> <td>Frequency range</td> <td style="text-align: right;">DC to 0.7GHz</td> </tr> <tr> <td>VSWR</td> <td style="text-align: right;">≤ 1.2 (DC to 0.7GHz)</td> </tr> <tr> <td>Insertion loss</td> <td style="text-align: right;">≤ 0.05dB</td> </tr> <tr> <td>Insulation resistance</td> <td style="text-align: right;">≥ 10000MΩ</td> </tr> <tr> <td>Contact resistance inner conductor</td> <td style="text-align: right;">≤ 0.4mΩ</td> </tr> <tr> <td>Contact resistance outer conductor</td> <td style="text-align: right;">≤ 1.5mΩ</td> </tr> <tr> <td>Dielectric withstanding voltage (at sea level)</td> <td style="text-align: right;">4000 V rms</td> </tr> <tr> <td>Working Voltage (at sea level)</td> <td style="text-align: right;">2700 V rms</td> </tr> <tr> <td>RF leakage</td> <td style="text-align: right;">≥ 128dB to 1GHz</td> </tr> </table>		Impedance	50Ω	Frequency range	DC to 0.7GHz	VSWR	≤ 1.2 (DC to 0.7GHz)	Insertion loss	≤ 0.05dB	Insulation resistance	≥ 10000MΩ	Contact resistance inner conductor	≤ 0.4mΩ	Contact resistance outer conductor	≤ 1.5mΩ	Dielectric withstanding voltage (at sea level)	4000 V rms	Working Voltage (at sea level)	2700 V rms	RF leakage	≥ 128dB to 1GHz
Impedance	50Ω																				
Frequency range	DC to 0.7GHz																				
VSWR	≤ 1.2 (DC to 0.7GHz)																				
Insertion loss	≤ 0.05dB																				
Insulation resistance	≥ 10000MΩ																				
Contact resistance inner conductor	≤ 0.4mΩ																				
Contact resistance outer conductor	≤ 1.5mΩ																				
Dielectric withstanding voltage (at sea level)	4000 V rms																				
Working Voltage (at sea level)	2700 V rms																				
RF leakage	≥ 128dB to 1GHz																				
<div style="border: 1px solid black; padding: 2px; margin-bottom: 5px;">Mechanical Data</div> <table style="width: 100%; border-collapse: collapse;"> <tr> <td style="width: 60%;">Recommended coupling nut torque</td> <td style="text-align: right;">260 inch lbs</td> </tr> <tr> <td>Coupling proof torque</td> <td style="text-align: right;">310 inch lbs</td> </tr> <tr> <td>Coupling nut retention force</td> <td style="text-align: right;">≥ 221 lbs</td> </tr> <tr> <td>Contact captivation-axial</td> <td style="text-align: right;">≥ 45 lbs</td> </tr> <tr> <td>Durability (mating)</td> <td style="text-align: right;">≥ 500</td> </tr> </table>		Recommended coupling nut torque	260 inch lbs	Coupling proof torque	310 inch lbs	Coupling nut retention force	≥ 221 lbs	Contact captivation-axial	≥ 45 lbs	Durability (mating)	≥ 500										
Recommended coupling nut torque	260 inch lbs																				
Coupling proof torque	310 inch lbs																				
Coupling nut retention force	≥ 221 lbs																				
Contact captivation-axial	≥ 45 lbs																				
Durability (mating)	≥ 500																				
<div style="border: 1px solid black; padding: 2px; margin-bottom: 5px;">Environmental Data</div> <table style="width: 100%; border-collapse: collapse;"> <tr> <td style="width: 60%;">Temperature range</td> <td style="text-align: right;">-65°C to +165°C</td> </tr> <tr> <td>Thermal shock</td> <td style="text-align: right;">MIL-STD-202, Method107, Condition B</td> </tr> <tr> <td>Moisture resistance</td> <td style="text-align: right;">MIL-STD-202, Method106</td> </tr> <tr> <td>Corrosion</td> <td style="text-align: right;">MIL-STD-202, Method101, Condition B</td> </tr> <tr> <td>RoHS</td> <td style="text-align: right;">Compliant</td> </tr> </table>		Temperature range	-65°C to +165°C	Thermal shock	MIL-STD-202, Method107, Condition B	Moisture resistance	MIL-STD-202, Method106	Corrosion	MIL-STD-202, Method101, Condition B	RoHS	Compliant										
Temperature range	-65°C to +165°C																				
Thermal shock	MIL-STD-202, Method107, Condition B																				
Moisture resistance	MIL-STD-202, Method106																				
Corrosion	MIL-STD-202, Method101, Condition B																				
RoHS	Compliant																				
<div style="border: 1px solid black; padding: 2px; margin-bottom: 5px;">Tooling</div> <table style="width: 100%; border-collapse: collapse;"> <tr> <td style="width: 60%;">Crimping tool</td> <td style="text-align: right;">CRT-1 or CRT-2</td> </tr> <tr> <td>Crimp insert</td> <td style="text-align: right;">INSERT-B</td> </tr> <tr> <td>Soldering gauge</td> <td style="text-align: right;">ST-0.4</td> </tr> </table>		Crimping tool	CRT-1 or CRT-2	Crimp insert	INSERT-B	Soldering gauge	ST-0.4														
Crimping tool	CRT-1 or CRT-2																				
Crimp insert	INSERT-B																				
Soldering gauge	ST-0.4																				

Notice: JYEBAO reserves the right to make modifications deemed appropriate.

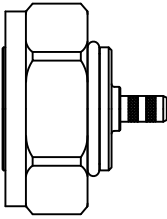
JYE BAO CO., LTD.

CABLE ASSEMBLY INSTRUCTION

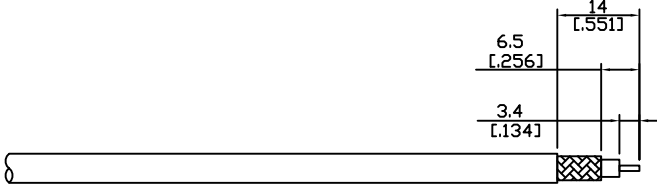
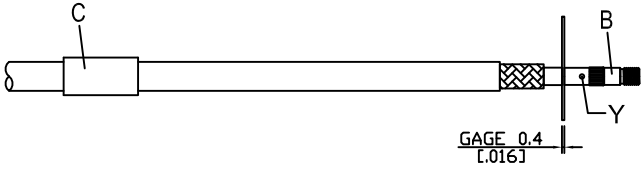
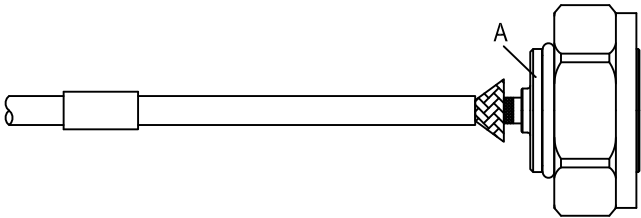
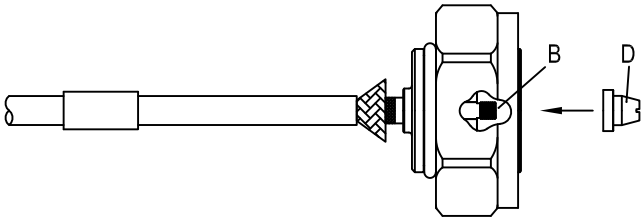
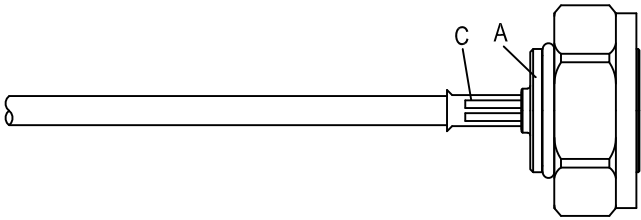
7/16-3100-0142	DATE	2014/04/29	REV	—
<p>A</p>  <p>BODY</p>	<p>B</p>  <p>CONTACT PIN</p>	<p>C</p>  <p>FERRULE</p>	<p>D</p>  <p>FERRULE</p>	
DIAGRAM	ASSEMBLY INSTRUCTION			
 <p>14 [.551] 6.5 [.256] 3.4 [.134]</p>	Step 1: STRIP AS SHOWN.			
 <p>C</p> <p>B</p> <p>Y</p> <p>GAGE .04 [.016]</p>	Step 2: SLIDE FERRULE " C " OVER CABLE. Step 3: PUT 0.4 MM GAGE ST-0.4 IN PLACE, INSERT CABLE'S CENTER CONDUCTOR INTO CONTACT PIN " B " AND SOLDER IN " Y ".			
 <p>A</p>	Step 4: LOOSEN BRAIDING AND SLIDE CONNECTOR " A " IN PLACE.			
 <p>B</p> <p>D</p>	Step 5: SCREW " D " ON CONTACT PIN " B ". (USE A FEW THREAD LOCKERS)			
 <p>C</p> <p>A</p>	Step 6: SLIDE FERRULE " C " TOWARDS THE CONNECTOR " A " AND CRIMP. (USE 5.5mm/0.217inch HEX SECTION OF INSERT-B)			
This part number complies with RoHS. Notice: JYEBAO reserves the right to make modifications deemed appropriate.				
APPROVED	CHECKED	DRAWING	<i>Albert</i>	

7/16-3100-0142

S11

