

2.4-8F46D-EM12	2.4mm Field Replaceable Jack, SQ 9.52mm (.375inch) 4 Hole Flange With Metal Ring, Accepts $\Phi 0.3\text{mm}$ (.012inch) Pin, 50GHz VSWR 1.18	50 $\Omega$
----------------	---	-------------

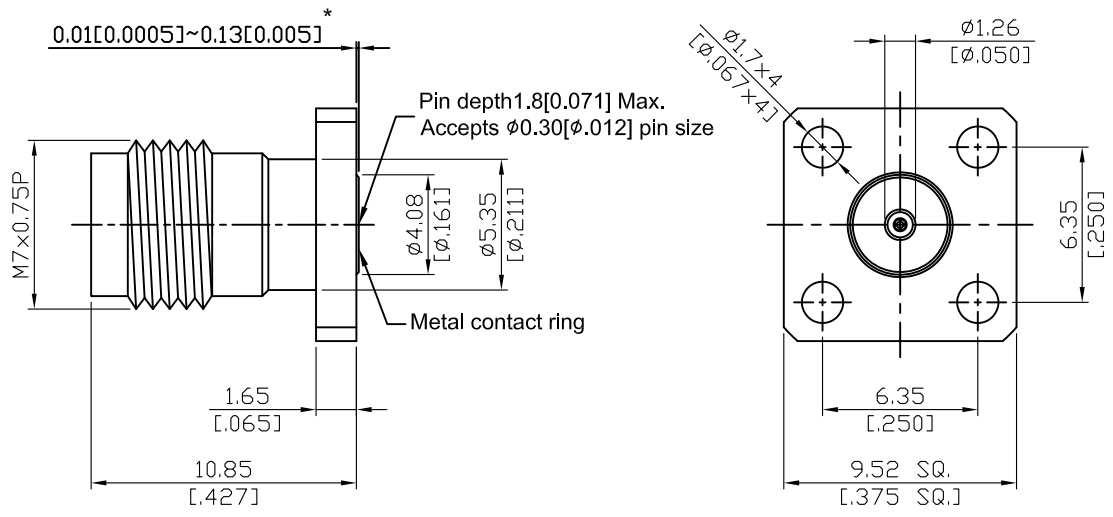

\*360° Raised Metal Contact Ring

Parts	Material	Plating ( Micro-inch )
Body	Stainless Steel	Passivated
Insulator	PEI	
Contact Pin	Beryllium Copper	Gold 4 Over Nickel-Phosphorus Alloy 80 Over Copper 20
Metal Contact Ring	Beryllium Copper	Gold 4 Over Nickel-Phosphorus Alloy 80 Over Copper 20

--	--

This part number complies with RoHS.  
 Notice: JYEBAO reserves the right to make modifications deemed appropriate.

2.4	2.4-8F46D-EM12
<div style="border: 1px solid black; padding: 2px; margin-bottom: 5px;">Interface</div> MIL-STD-348B Mechanically compatible with 1.85	
<div style="border: 1px solid black; padding: 2px; margin-bottom: 5px;">Electrical Data</div> Impedance 50Ω Frequency range DC to 50GHz VSWR $\leq 1.18$ (DC to 50GHz) Insertion loss $\leq 0.05 \times \sqrt{f(\text{GHz})}$ dB Insulation resistance $\geq 5000\text{M}\Omega$ Contact resistance inner conductor $\leq 4\text{m}\Omega$ Contact resistance outer conductor $\leq 2.5\text{m}\Omega$ Dielectric withstanding voltage (sea level) 500V rms Working voltage (sea level) 150V rms RF leakage $\geq 100\text{dB}$ to 1GHz	
<div style="border: 1px solid black; padding: 2px; margin-bottom: 5px;">Mechanical Data</div> Recommended coupling nut torque 7.08 to 9.74 inch lbs Coupling proof Torque 15 inch lbs Contact captivation-axial $\geq 4.5$ lbs Durability (mating) $\geq 500$	
<div style="border: 1px solid black; padding: 2px; margin-bottom: 5px;">Environmental Data</div> Temperature range -40°C to +165°C Thermal shock MIL-STD-202, Method 107, Condition B Moisture resistance MIL-STD-202, Method 106 Corrosion MIL-STD-202, Method 101, Condition B RoHS Compliant	
<div style="border: 1px solid black; padding: 2px; margin-bottom: 5px;">Accessories</div> Hermetic seal FR012-SEAL1; FR012-SEAL2; SEAL.012 Launch pin & Dielectric transition FR012-LAUNCH1; FR012-LAUNCH2 Tab pin & Dielectric transition FR012-TAB2; FR012-TAB3 Tab pin FR012-TAB1	

Notice: JYEBAO reserves the right to make modifications deemed appropriate.

## Recommended Launch Hole Dimensions :

### 1. Using Hermetic seals

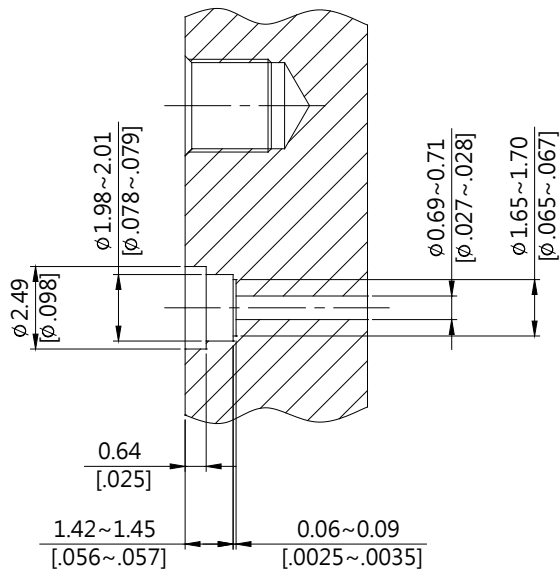

Hermetic seal P/N

SEAL.012

FR012-SEAL1

FR012-SEAL2

### 2. Using dielectric with Tab or Launch pin

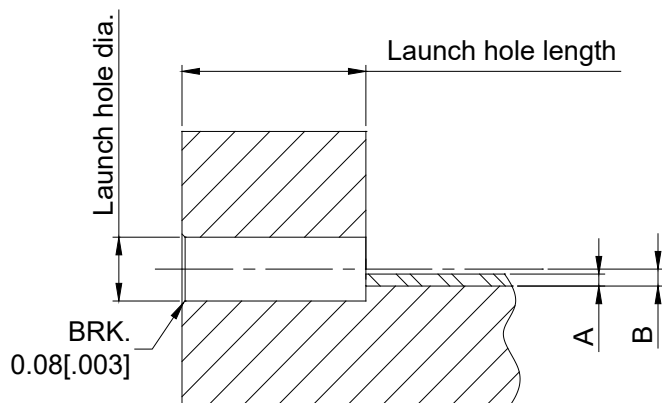

"A" = Substrate thickness

"B" = A + 1/2 Tab or Launch terminal

Dielectric and Tab/Launch pin P/N	Recommended Launch hole dia.	Recommended Launch hole length
FR012-LAUNCH1	$\phi$ 0.99 (.039)	4.75 (.187)
FR012-LAUNCH2	$\phi$ 0.99 (.039)	3.18 (.125)
FR012-TAB2	$\phi$ 0.99 (.039)	3.18 (.125)
FR012-TAB3	$\phi$ 0.99 (.039)	4.75 (.187)

### 3. Using Tab pin

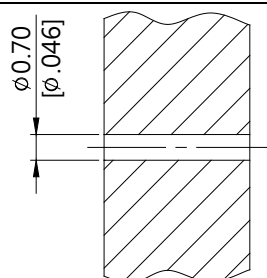

Tab pin P/N

FR012-TAB1

# 2.4-8F46D-EM12

S11

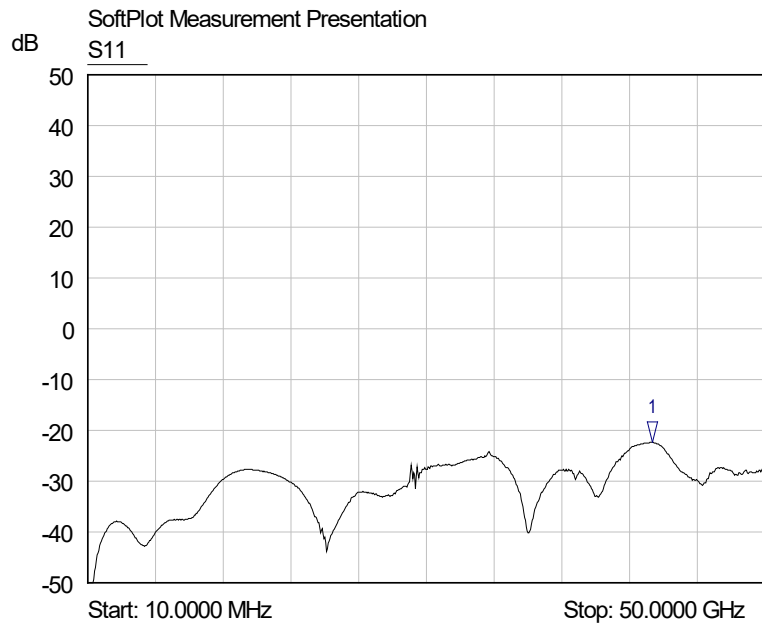

1 S11  
▽ 41.6788 GHz  
-22.35 dB