

NO.	COMPONENTS	IMPEDANCE
1	1.85 FEMALE	50 OHM
2	5002A	50 OHM
3	SLEEVE	
4	1.85 NMD FEMALE	50 OHM

REVISION			
REV.	DESCRIPTON	DATE	APPROVED
-	INITIAL RELEASE	2020/12/07	

1.85 FEMALE

1.85 NMD FEMALE

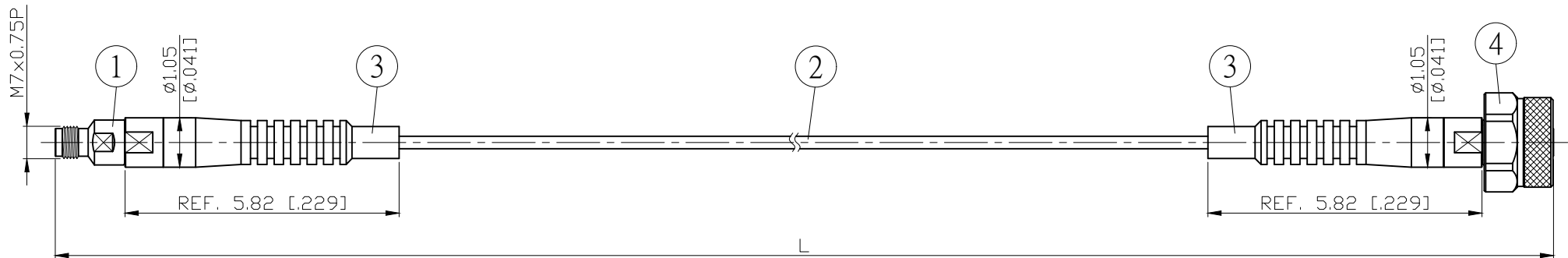

L CM (INCH)	L1 M (MM)
50 (19.685)	0.478 (478.0)
100 (39.370)	0.978 (978.0)
150 (59.055)	1.478 (1478.0)
200 (78.740)	1.978 (1978.0)
Custom length in CM	- - -

Spec	Phase stability vs bending ⁽¹⁾	Amplitude stability vs bending ⁽²⁾	Max VSWR	Max IL	Flexure life cycle ⁽³⁾
3GHz	$\pm 0.3^\circ$ typ / $\pm 0.5^\circ$ max	± 0.005 dB typ / ± 0.01 dB max	1.12 : 1	$\leq (0.0128\text{dB/cm} * L_{\text{cm}}) + 0.15\text{dB}$	≥ 100000
6GHz	$\pm 0.5^\circ$ typ / $\pm 0.75^\circ$ max	± 0.0075 dB typ / ± 0.015 dB max	1.15 : 1	$\leq (0.0189\text{dB/cm} * L_{\text{cm}}) + 0.20\text{dB}$	
12.4GHz	$\pm 0.75^\circ$ typ / $\pm 1.0^\circ$ max	± 0.01 dB typ / ± 0.02 dB max	1.20 : 1	$\leq (0.0293\text{dB/cm} * L_{\text{cm}}) + 0.25\text{dB}$	
18GHz	$\pm 1.0^\circ$ typ / $\pm 1.5^\circ$ max	± 0.015 dB typ / ± 0.03 dB max	1.25 : 1	$\leq (0.0361\text{dB/cm} * L_{\text{cm}}) + 0.30\text{dB}$	
26.5GHz	$\pm 1.5^\circ$ typ / $\pm 2.0^\circ$ max	± 0.02 dB typ / ± 0.04 dB max	1.25 : 1	$\leq (0.0450\text{dB/cm} * L_{\text{cm}}) + 0.40\text{dB}$	
40GHz	$\pm 2.0^\circ$ typ / $\pm 3.5^\circ$ max	± 0.03 dB typ / ± 0.06 dB max	1.30 : 1	$\leq (0.0568\text{dB/cm} * L_{\text{cm}}) + 0.50\text{dB}$	
50GHz	$\pm 3.0^\circ$ typ / $\pm 8.0^\circ$ max	± 0.04 dB typ / ± 0.08 dB max	1.30 : 1	$\leq (0.0640\text{dB/cm} * L_{\text{cm}}) + 0.70\text{dB}$	
70GHz	$\pm 5.0^\circ$ typ / $\pm 10^\circ$ max	± 0.05 dB typ / ± 0.10 dB max	1.35 : 1	$\leq (0.0800\text{dB/cm} * L_{\text{cm}}) + 0.80\text{dB}$	

Notes:

- Operating Temp.: -40°C / $+105^\circ\text{C}$
- Static bend radius 5.1mm
- Dynamic bend radius 20mm
- RoHS Compliant

- (1) Per IEC 60966-1, section 8.6, method 1
- (2) Per IEC 60966-1, section 8.4
- (3) Per IEC 60966-1, section 9.3

					STANDARD	REV -	UNIT CM(INCH)	JYE BAO CO., LTD.	
					APPROVED			TAIPEI TAIWAN	
					CHECKED			DESCRIPTION CABLE ASSEMBLY 1.85 JACK TO 1.85 NMD JACK	
					DRAWING			JYE BAO DRAWING NO. 1880188N-52A-70GXXX	
4	U-1.85N-F	1.85 NMD JACK	1	EA	LENGTH TOLERANCE IS $\pm 1.5\%$ OR $\pm 10\text{MM}$, WHICHEVER IS GREATER.				
3	U-5002A	SLEEVE	2	EA					
2	5002A	CABLE	SEE TABLE L1	M					
1	U-1.85-F	1.85 JACK	1	EA					
NO.	PARTS NO.	DESCRIPTION	Q'TY	U/M					

Albert