

NO.	COMPONENTS	IMPEDANCE
1	1.85 FEMALE	50 OHM
2	5002A	50 OHM
3	SLEEVE	

REVISION			
REV.	DESCRIPTON	DATE	APPROVED
-	INITIAL RELEASE	2020/12/10	

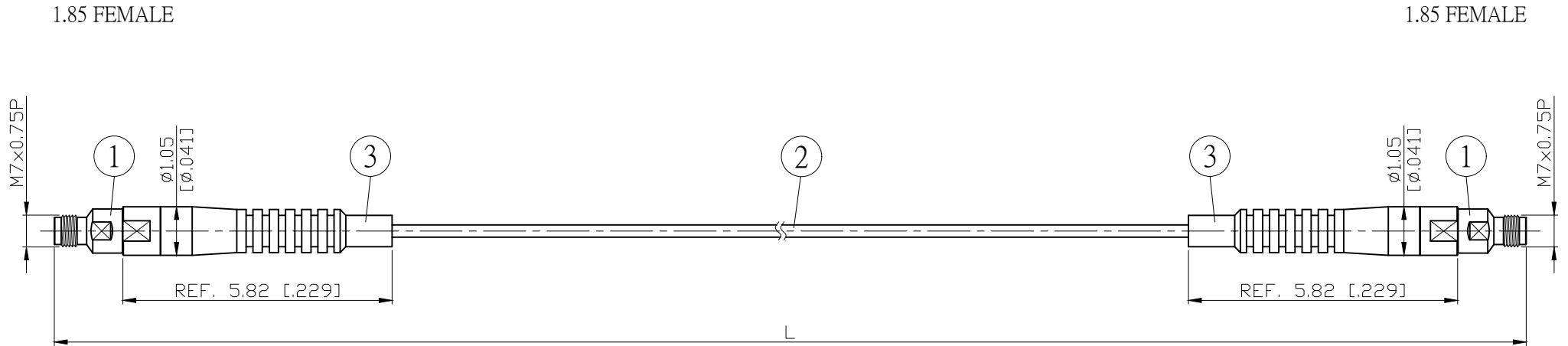

L CM (INCH)	L1 M (MM)
50 (19.685)	0.479 (478.5)
100 (39.370)	0.979 (978.5)
150 (59.055)	1.479 (1478.5)
200 (78.740)	1.979 (1978.5)
Custom length in CM	- - -

Spec	Phase stability vs bending ⁽¹⁾	Amplitude stability vs bending ⁽²⁾	Max VSWR	Max IL	Flexure life cycle ⁽³⁾
3GHz	±0.3° typ / ±0.5° max	±0.005dB typ / ±0.01dB max	1.12 : 1	≤ (0.0128dB/cm*Lcm)+0.15dB	≥ 100000
6GHz	±0.5° typ / ±0.75° max	±0.0075dB typ / ±0.015dB max	1.15 : 1	≤ (0.0189dB/cm*Lcm)+0.20dB	
12.4GHz	±0.75° typ / ±1.0° max	±0.01dB typ / ±0.02dB max	1.20 : 1	≤ (0.0293dB/cm*Lcm)+0.25dB	
18GHz	±1.0° typ / ±1.5° max	±0.015dB typ / ±0.03dB max	1.25 : 1	≤ (0.0361dB/cm*Lcm)+0.30dB	
26.5GHz	±1.5° typ / ±2.0° max	±0.02dB typ / ±0.04dB max	1.25 : 1	≤ (0.0450dB/cm*Lcm)+0.40dB	
40GHz	±2.0° typ / ±3.5° max	±0.03dB typ / ±0.06dB max	1.30 : 1	≤ (0.0568dB/cm*Lcm)+0.50dB	
50GHz	±3.0° typ / ±8.0° max	±0.04dB typ / ±0.08dB max	1.30 : 1	≤ (0.0640dB/cm*Lcm)+0.70dB	
70GHz	±5.0° typ / ±10° max	±0.05dB typ / ±0.10dB max	1.35 : 1	≤ (0.0800dB/cm*Lcm)+0.80dB	

Notes:

1. Operating Temp.: -40°C / +105°C
2. Static bend radius 5.1mm
3. Dynamic bend radius 20mm
4. RoHS Compliant

- (1) Per IEC 60966-1, section 8.6, method 1
- (2) Per IEC 60966-1, section 8.4
- (3) Per IEC 60966-1, section 9.3

					STANDARD	REV -	UNIT CM(INCH)	JYE BAO CO., LTD.	
					APPROVED			TAIPEI TAIWAN	
					CHECKED	DATE		DESCRIPTION	
					DRAWING	DATE		CABLE ASSEMBLY 1.85 JACK TO 1.85 JACK	
					<i>Albert</i>	DATE		JYE BAO DRAWING NO.	
						DATE		18801880-52A-70GXXX	
3	U-5002A	SLEEVE	2	EA					
2	5002A	CABLE	SEE TABLE L1	M					
1	U-1.85-F	1.85 JACK	2	EA					
NO.	PARTS NO.	DESCRIPTION	Q'TY	U/M					