

1.85-8F26E-GA09

1.85mm Field Replaceable Jack,
 $\phi 13.97\text{mm}$ (.550inch) 2 Hole Flange With EMI Gasket,
 Accepts $\phi 0.23\text{mm}$ (.009inch) Pin, 67GHz VSWR 1.25

50 Ω

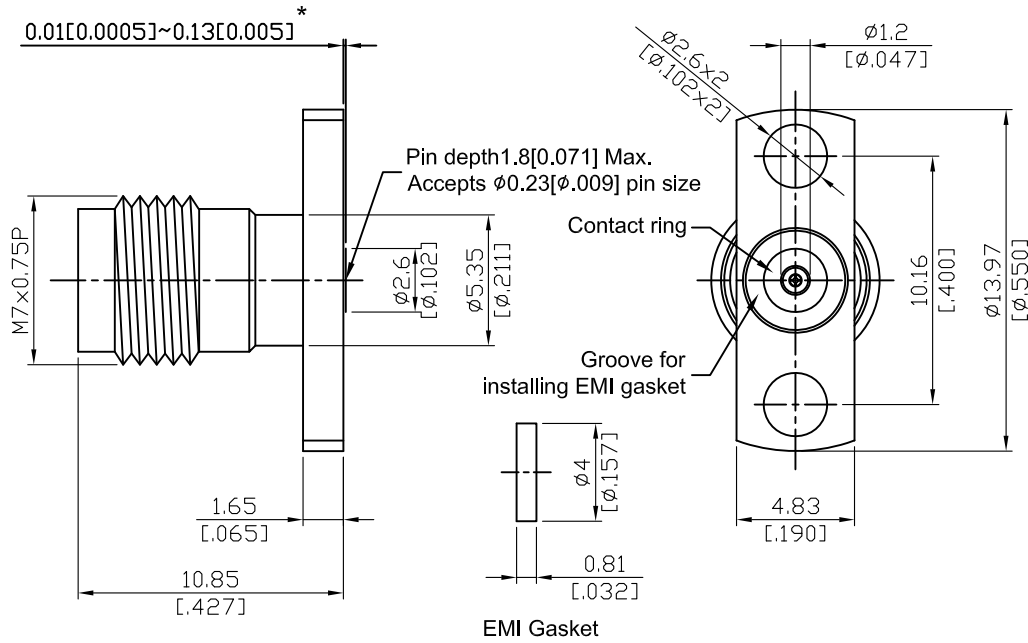

*360° Raised Metal Contact Ring

Parts	Material	Plating (Micro-inch)
Body	Stainless Steel	Passivated
Insulator	PEI	
Contact Pin	Beryllium Copper	Gold 4 Over Nickel-Phosphorus Alloy 80 Over Copper 20
Contact Ring	Stainless Steel	Passivated
EMI Gasket	Conductive Silicone Elastomers	

1.85	1.85-8F26E-GA09
<div style="border: 1px solid black; padding: 2px; margin-bottom: 5px;">Interface</div> IEEE 287; IEC61169-32 Mechanically compatible with 2.4	
<div style="border: 1px solid black; padding: 2px; margin-bottom: 5px;">Electrical Data</div> Impedance 50Ω Frequency range DC to 67GHz VSWR ≤ 1.25 (DC to 67GHz) Insertion loss $\leq 0.05 \times \sqrt{f(\text{GHz})}$ dB Insulation resistance $\geq 5000\text{M}\Omega$ Contact resistance inner conductor $\leq 4\text{m}\Omega$ Contact resistance outer conductor $\leq 2.5\text{m}\Omega$ Dielectric withstanding voltage (sea level) 500V rms Working voltage (sea level) 150V rms RF leakage $\geq 100\text{dB}$ to 1GHz	
<div style="border: 1px solid black; padding: 2px; margin-bottom: 5px;">Mechanical Data</div> Recommended coupling nut torque 7.08 to 9.74 inch lbs Coupling proof Torque 15 inch lbs Contact captivation-axial ≥ 4.5 lbs Durability (mating) ≥ 500	
<div style="border: 1px solid black; padding: 2px; margin-bottom: 5px;">Environmental Data</div> Temperature range -40°C to +150°C Thermal shock MIL-STD-202, Method 107, Condition B Moisture resistance MIL-STD-202, Method 106 Corrosion MIL-STD-202, Method 101, Condition B RoHS Compliant	
<div style="border: 1px solid black; padding: 2px; margin-bottom: 5px;">Accessories</div> Hermetic seal FR009-SEAL1 Launch pin & Dielectric transition FR009-LAUNCH1; FR009-LAUNCH2 Tab pin & Dielectric transition FR009-TAB2; FR009-TAB3 Tab pin FR009-TAB1	

Notice: JYEBAO reserves the right to make modifications deemed appropriate.

Recommended Launch Hole Dimensions :

1. Using Hermetic seals

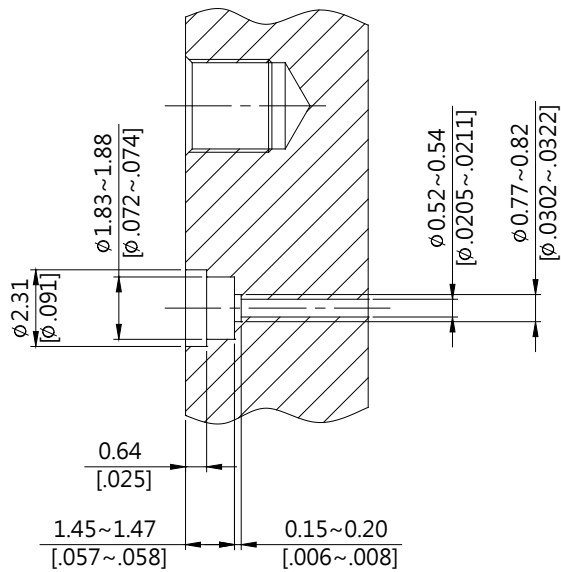

Hermetic seal P/N

FR009-SEAL1

2. Using dielectric with Tab or Launch pin



"A" = Substrate thickness

"B" = A + 1/2 Tab or Launch terminal

Dielectric and Tab/ Launch pin P/N	Recommended Launch hole dia.	Recommended Launch hole length
FR009-LAUNCH1	$\phi 0.74 (.029)$	4.75 (.187)
FR009-LAUNCH2	$\phi 0.74 (.029)$	3.18 (.125)
FR009-TAB2	$\phi 0.74 (.029)$	3.18 (.125)
FR009-TAB3	$\phi 0.74 (.029)$	4.75 (.187)

3. Using Tab pin



Tab pin P/N

FR009-TAB1