

1.85-8F26A-EM12

1.85mm Field Replaceable Jack,
 $\phi 15.9\text{mm}$ (.625inch) 2 Hole Flange With Metal Ring,
 Accepts $\phi 0.3\text{mm}$ (.012inch) Pin, 67GHz VSWR 1.25

50 Ω

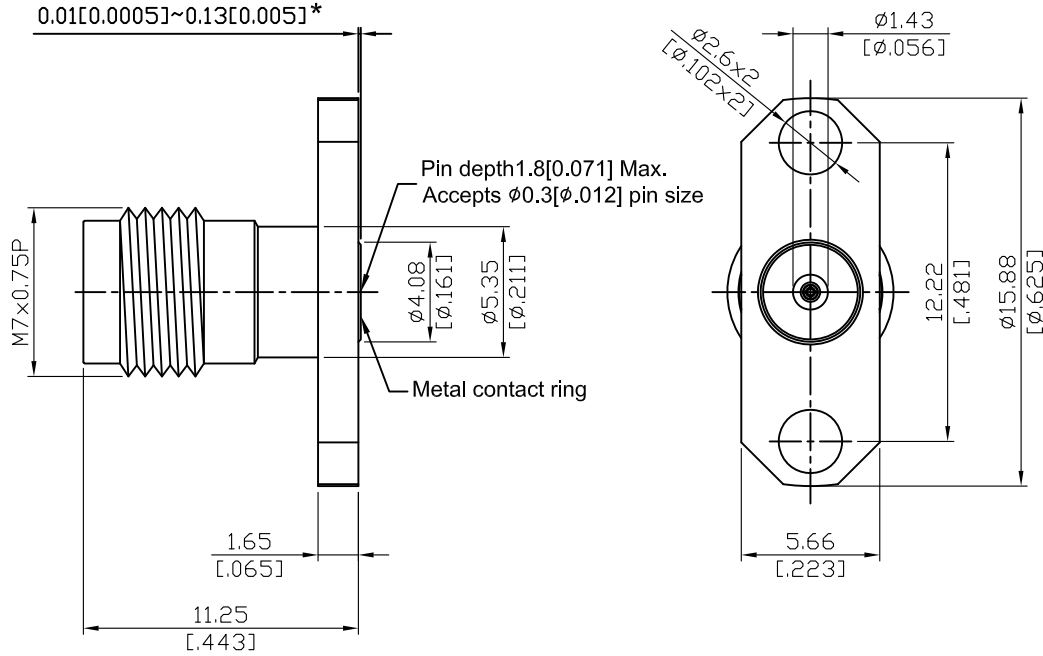

*360° Raised Metal Contact Ring

Parts	Material	Plating (Micro-inch)
Body	Stainless Steel	Passivated
Insulator	PEI	
Contact Pin	Beryllium Copper	Gold 4 Over Nickel-Phosphorus Alloy 80 Over Copper 20
Metal Contact Ring	Beryllium Copper	Gold 4 Over Nickel-Phosphorus Alloy 80 Over Copper 20

This part number complies with RoHS.

Notice: JYEBAO reserves the right to make modifications deemed appropriate.

1.85	1.85-8F26A-EM12
<div data-bbox="113 327 513 376" style="border: 1px solid black; padding: 2px;">Interface</div> <p>IEEE 287; IEC61169-32</p> <p>Mechanically compatible with 2.4</p>	
<div data-bbox="113 490 513 539" style="border: 1px solid black; padding: 2px;">Electrical Data</div> <p>Impedance 50Ω</p> <p>Frequency range DC to 67GHz</p> <p>VSWR ≤ 1.25 (DC to 67GHz)</p> <p>Insertion loss ≤ 0.05 x √f(GHz) dB</p> <p>Insulation resistance ≥ 5000MΩ</p> <p>Contact resistance inner conductor ≤ 4mΩ</p> <p>Contact resistance outer conductor ≤ 2.5mΩ</p> <p>Dielectric withstanding voltage (sea level) 500V rms</p> <p>Working voltage (sea level) 150V rms</p> <p>RF leakage ≥ 100dB to 1GHz</p>	
<div data-bbox="113 1084 513 1133" style="border: 1px solid black; padding: 2px;">Mechanical Data</div> <p>Recommended coupling nut torque 7.08 to 9.74 inch lbs</p> <p>Coupling proof Torque 15 inch lbs</p> <p>Contact captivation-axial ≥ 4.5 lbs</p> <p>Durability (mating) ≥ 500</p>	
<div data-bbox="113 1391 513 1440" style="border: 1px solid black; padding: 2px;">Environmental Data</div> <p>Temperature range -40°C to +165°C</p> <p>Thermal shock MIL-STD-202, Method 107, Condition B</p> <p>Moisture resistance MIL-STD-202, Method 106</p> <p>Corrosion MIL-STD-202, Method 101, Condition B</p> <p>RoHS Compliant</p>	
<div data-bbox="113 1744 513 1794" style="border: 1px solid black; padding: 2px;">Accessories</div> <p>Hermetic seal FR012-SEAL1; FR012-SEAL2; SEAL.012</p> <p>Launch pin & Dielectric transition FR012-LAUNCH1; FR012-LAUNCH2</p> <p>Tab pin & Dielectric transition FR012-TAB2; FR012-TAB3</p> <p>Tab pin FR012-TAB1</p>	

Notice: JYEBAO reserves the right to make modifications deemed appropriate.

Recommended Launch Hole Dimensions :

1. Using Hermetic seals



Hermetic seal P/N

SEAL.012

FR012-SEAL1

FR012-SEAL2

2. Using dielectric with Tab or Launch pin



"A" = Substrate thickness

"B" = A + 1/2 Tab or Launch terminal

Dielectric and Tab/Launch pin P/N	Recommended Launch hole dia.	Recommended Launch hole length
FR012-LAUNCH1	$\phi 0.99 (.039)$	4.75 (.187)
FR012-LAUNCH2	$\phi 0.99 (.039)$	3.18 (.125)
FR012-TAB2	$\phi 0.99 (.039)$	3.18 (.125)
FR012-TAB3	$\phi 0.99 (.039)$	4.75 (.187)

3. Using Tab pin



Tab pin P/N

FR012-TAB1